

Digital Differential Pressure Type Split-display Flow Meter

CHELIC

FP-D series

Applicable

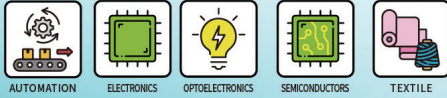

CO₂ Emission Statistics Environmental Management



- Precision is not affected by gas temperature
- Cost reduction by reducing piping components
- Split display allows for remote data management

Wide flow range

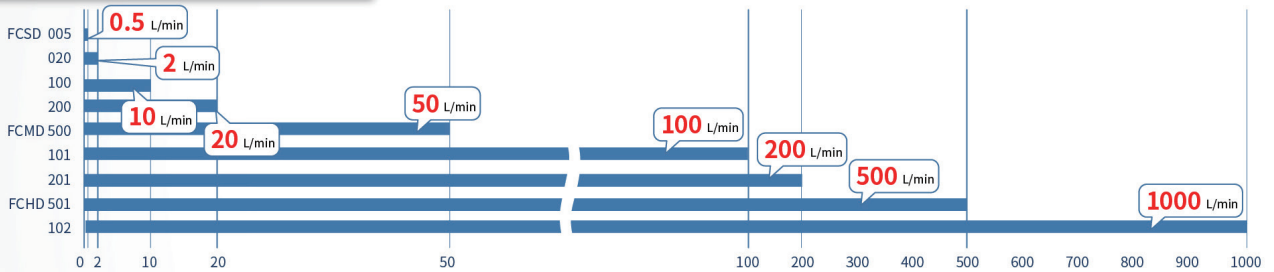

Carbon measurement and energy saving



Energy saving mode
(Auto Sleep Mode)



CO₂ Emission Statistics
Manage Carbon Footprint

Operation Principle

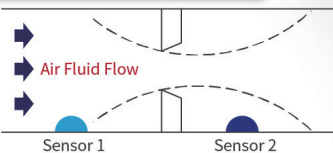

Flows are calculated from pressure differences

Two-color display

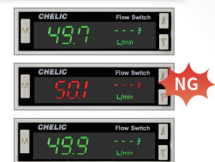

Directly identifies abnormalities quickly

Quick Answer

Response time
50 msec



High Level of Protection

Meet IEC specifications



High Accuracy

Repeat accuracy
± 1 %F.S. or less



FP-D series Digital Differential Pressure Type Split-display Flow Meter

Product features

CHELIC

Feature

- Horizontal display function.
- Split display, optimized visibility.



Specification

Item	Model	FPSD		FPM D			FPH D	
Flow rate (L/min)		10	20	50	100	200	500	1000
Port size		Ø4, Ø6		Ø6, Ø8	Ø8		PT 1/2"	
Measure fluid		Air, Nitrogen <small>Note 2</small>						
Flow unit <small>Note 1</small>	Display	2 color LCD						
	Displayable range (L/min)	0 ~ 10	0 ~ 20	0 ~ 50	0 ~ 100	0 ~ 200	0 ~ 500	0 ~ 1000
	Min. display unit (L/min)	0.01	0.1			1		
Accumulated pulse flow function	Displayable range (L)	99999.99	999999.9			9999999		
	Min. display unit (L)	0.01	0.1			1		
Power Type	Voltage	DC 24 V (±10%)						
Current consumption		50 mA or below <small>Note 5</small>						
Response time		50 ms or below						
Environment <small>Note 2</small>	Min. operating pressure (MPa)	0.1						
	Max. operating pressure (MPa)	0.7						
	Proof pressure (MPa)	1						
	Ambient of fluid temperature (°C)	0 ~ 50 (No ice, no frost)						
	Ambient of fluid humidity (RH)	90% or below						
	Operating temperature range (°C)	0 ~ 50 (No ice, no frost)						
Accuracy (F.S.) <small>Note 3</small>	Operating range	3 ~ 100%						
	Linearity	within ±3% (The secondary atmospheric release)						
	Pressure characteristics	within ±2%						
	Temperature characteristics	within ±0.2% F.S./°C (15~35°C, 25°C base)						
	Repeatability	within ±1%						
Output type	Analog output	Voltage output: 1 ~ 5 V, Load Impedance: 50 kΩ Current output: 4 ~ 20 mA, Load Impedance: 300 Ω <small>Note 4</small>						
Wiring		Ø3.8mm, AWG26 X 5 Core						
Enclosure <small>Note 6</small>		IP40						
Circuit protection		Reverse power connect protection						
Weight		56						141

Note:

1. Converted to volumetric flow at 25° C of 1 barometric pressure (101 kPa).
2. When applying compressed air, please use clean air that complies to JIS B 8392-1:2003 Class 1.1.1 to 1.6.2. Compressed air from the compressor contains drainage (water, oxidized oil, foreign matter, etc.). Install an air dryer (minimum pressure dew point: 10° C or colder), and oil mist filter (maximum oil concentration: 0.1 mg/m3) on the primary side of this product to maintain product functions.
3. Please calibrate the product within specification requested. The environment condition: 25± 3° C, voltage output DC 24V +/- 0.1V. F.S. indicates the actual portion of flow rate.
4. When the connection to load impedance is low, the output value differentiation will increase. Please do make sure the connection of load impedance difference before use.
5. Current for 24 VDC connection with no load connected. Consumed current varies with the load connection.
6. This product's protection circuit is effective only for specific misconnections and load short-circuits. It does not provide protection for all misconnections.
7. Please refer to P.1-4.153 for FP-D precautions.

FP-D series Digital Differential Pressure Type Split-display Flow Meter

Product features

CHELIC

Feature

- Connected way, simple wiring.
- Unlimited installation methods.
- Display interface, easy to install and managed.



Specification

Item	Model	FPD
Setting flow range (L/min) <small>Note 1</small>		10, 20, 50, 100, 200, 500, 1000
Ambient of fluid temperature (°C)		0 ~ 50 (No icing, no frosting)
Display type		4 digit + 4 digit; 2 color LCD display
Input voltage (V)		1 ~ 5
Output type	Analog output	Voltage output: 1 ~ 5 V, Load Impedance: 50 kΩ <small>Note 4, 5</small>
	Switch output	2 NPN open collector output, 50mA or below, voltage dropping
Power supply voltage (V)		DC 12 ~ 24 (10.8 ~ 26.4)
Current consumption <small>Note 2</small>		Below 40mA (when reach to DC24V, load impedance)
Wiring		Ø3.8mm is AWG 26 x 5 core (connector), insulator outer dia. Ø1.0mm
Function		Flow display, flow display to peak holding, on-off output, analog output
Enclosure		IEC standard equal to IP 40
Circuit protection <small>Note 3</small>		Reverse power connect protection
Accessory		1 sensing connector with 1 meter cable
Weight (body only) (g)		about 16

Note: 1. When connecting FP monitor, it detects flow range automatically (The setting will be down before delivery).

2. Current for 24 VDC connection with no load connected. Consumed current varies with the load connection.

3. This product's protection circuit is effective only for specific misconnections and load short-circuits. It does not provide protection for all misconnections.

4. Analog output is with load impedance 1kΩ. When the connection to load impedance is low, the output value differentiation will increase. Please do make sure the connection of load impedance difference before use.

5. Please refer to P.1-4.153 for FP-D precautions.

CVTR

CVAR

CVFR

CMT

CMA

FU

MF

FPF

FP

FP-D

FPX

FPZ

FPG

FC

FC-D

FC-R

FC-J

FC-K

FP-D series Digital Differential Pressure Type Split-display Flow Meter

Model selection

CHELIC

Sequence 1 Flow range selection

Flow reference table

Flow	Measuring flow range	F.S. flow deviation
500 mL	15 mL ~ 500 mL	±15 mL
2 L	0.06 L ~ 2 L	±0.06 L
10 L	0.3 L ~ 10 L	±0.3 L
20 L	0.6 L ~ 20 L	±0.6 L
50 L	1.5 L ~ 50 L	±1.5 L
100 L	3 L ~ 100 L	±3 L
200 L	6 L ~ 200 L	±6 L
500 L	15 L ~ 500 L	±15 L
1000 L	30 L ~ 1000 L	±30 L

- F.S. flow deviation (allowable error $\pm 3\%$)
ex: 10 L (1000 mL) flowmeter 1000 mL* $\pm 3\%$ accuracy error is equal to error value of ± 300 mL. If the target flow rate is 300 mL, its 0 ~ 600 mL is within the allowable range. If the error value is required to ± 60 mL, 2 L is recommended Specification flowmeter. (If the flow rate is larger, the allowable error range is larger)
- Before selecting a flow meter, you need to determine the flow range you used.
ex: Flow meter is 30 L, 50 L can be selected; 150 L can be 200 L
- Pay attention to the Min. flow range for the flowmeter.
ex: 1000 L is at least 30 L, so the flow rate below 30 L will be incompatible
- If the rate is higher than 3%F.S., the flowmeter will display H.
ex: The maximum allowable error value of 1000 L is 1060 L, if it is higher than 1060 L, H will be displayed.

Sequence 2 Port size selection

- Confirm whether the connection diameter of the product can meet your requirements also the specifications on the catalog.
(EX: 500 type connection caliber only $\varnothing 6$ and $\varnothing 8$ specifications can be used directly)
- It is recommended that the pipeline before the inlet and outlet ports is greater than or equal to the diameter of the connecting pipe. If it is lower than the pipe diameter, it may cause flow restriction.

Sequence 3 Analog output and switch output selection

- The output signal has voltage and current options, please confirm the output signal and choose.

Output signal	Voltage type	DC 1 ~ 5 V
	Current type	DC 4 ~ 20 mA
Output impedance	Voltage type	50 k Ω
	Current type	300 Ω

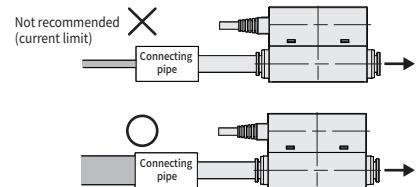

The flow meter body features clear and intuitive indicator lights to determine flow rate, and its output function supports only analog output. For switch output functionality, a split-display unit is required.

- Confirm the switch signal NPN or PNP type.

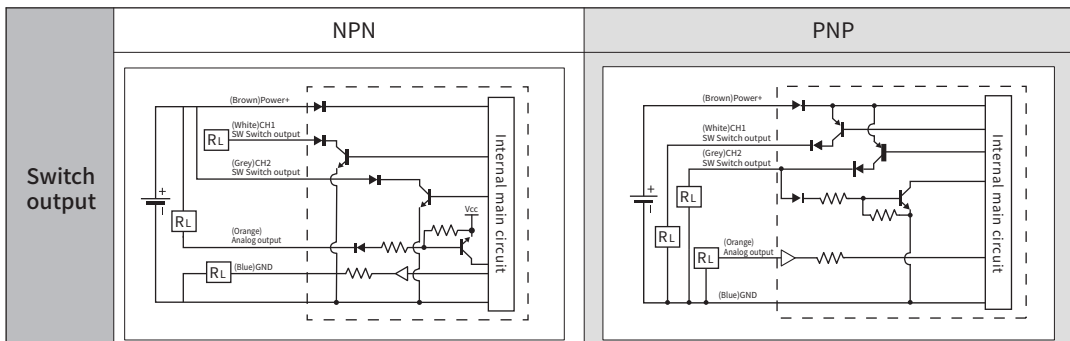

FP-D series Digital Differential Pressure Type Split-display Flow Meter

Code of order

CHELIC

Code of order-Separateable flow switch

FP SD - 100 - C04 - V - B - 3

1 — 2 — 3 — 4 — 5 — 6

1

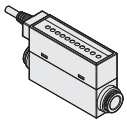

Mark	Type
SD	Small flow rate
MD	Medium Flow rate
HD	Large flow rate

2

Model	Mark	Flow(L/min)
FPSD	100	10
	200	20
FPMD	500	50
	101	100
	201	200
FPHD	501	500
	102	1000

3

Mark	Port size	FPSD		FPMD		FPHD	
		100	200	500	101	201	501
C04	Ø4	●	●	—	—	—	—
C06	Ø6	●	●	●	—	—	—
C08	Ø8	—	—	●	●	●	—
P04	PT1/2"	—	—	—	—	—	● ●

6

Mark	Cable Connector
None	Without cable
1	1 m
3	3 m

4

Mark	Monitor Output
V	Voltage type 1 ~ 5 V
A	Current type 4 ~ 20 mA

● The current type is a special specification product. Please contact sales for orders.

5

Mark	Bracket	FPSD	FPMD	FPHD
None	—	No bracket		
B	Flat bracket	●	●	—
L	L type bracket	●	●	●

● Image

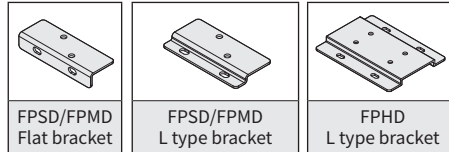

Code of order-Separateable Flow Switch

(This product is for numerical display only without flow sensing function.)

FPD - 100 - V - N - F - 3

7 — 8 — 9 — 10 — 11 — 12

7

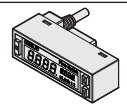

FPD

8

Model	Mark	Flow(L/min)
FPD	100	10
	200	20
	500	50
	101	100
	201	200
	501	500
	102	1000

9

Mark	Monitor Output
V	Voltage type 1 ~ 5 V
A	Current type 4 ~ 20 mA

● The current type is a special specification product. Please contact sales for orders.

10

Mark	Switch Output
N	NPN Output
P	PNP Output

11

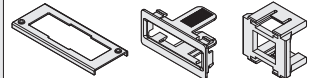
Mark	Type
None	Without accessory
F	Monitor assembly accessory
	

12

Mark	Cable Connector
None	Without cable
1	1 m
3	3 m

CVTR

CVAR

CVFR

CMT

CMA

FU

MF

FPF

FP

FP-D

FPX

FPZ

FPG

FC

FC-D

FC-R

FC-J

FC-K

FP-D series Digital Differential Pressure Type Split-display Flow Meter

Characteristics graph

CHELIC

Pressure loss characteristics

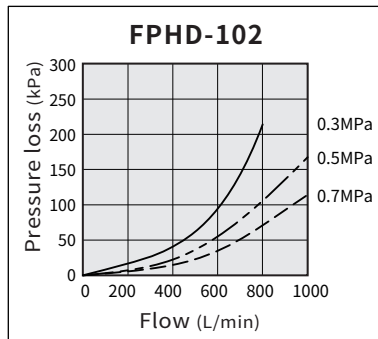
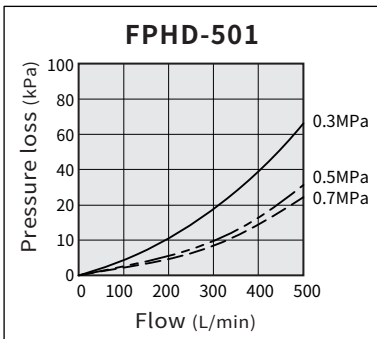
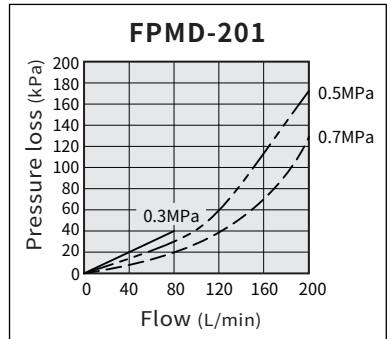
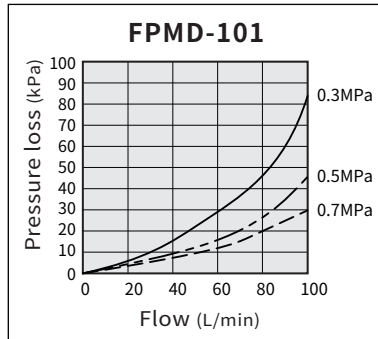
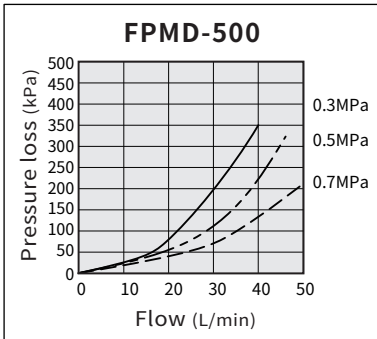
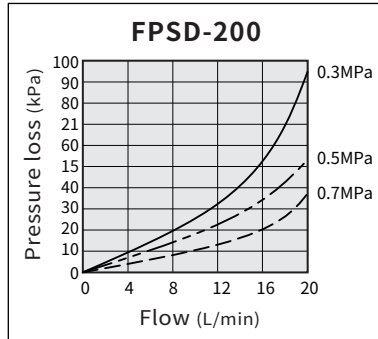
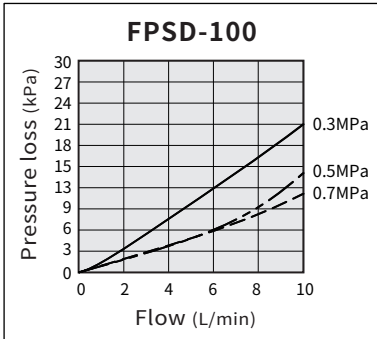

FP-D series Digital Differential Pressure Type Split-display Flow Meter

Product features

CHELIC

FPSD

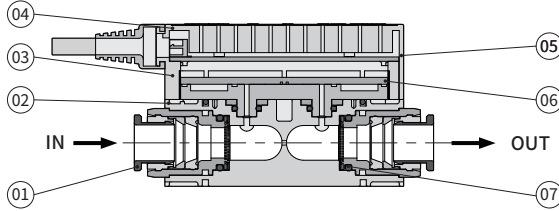

Components and material list

No.	Item	Material
01	Fitting assembly	Copper
02	Main body	Nylon fiber
03	Cover of sensor module	Nylon
04	Cover	ABS resin
05	Upper display panel	PCB
06	Flow sensor module	PCB
07	Fairing board	Stainless steel

FPMD

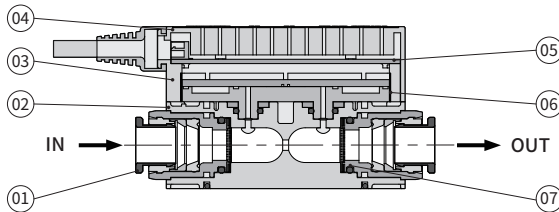

Components and material list

No.	Item	Material
01	Fitting assembly	Copper
02	Main body	Nylon fiber
03	Cover of sensor module	Nylon
04	Cover	ABS resin
05	Upper display panel	PCB
06	Flow sensor module	PCB
07	Fairing board	Stainless steel

FPHD

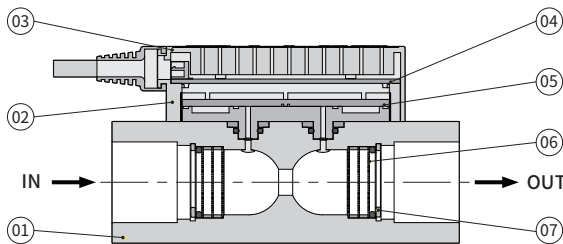

Components and material list

No.	Item	Material
01	Main body	Aluminum material
02	Cover of sensor module	Nylon
03	Cover	ABS resin
04	Upper display panel	PCB
05	Flow sensor module	PCB
06	Fairing board	Stainless steel
07	O-ring	Stainless steel

FPD

Display component list

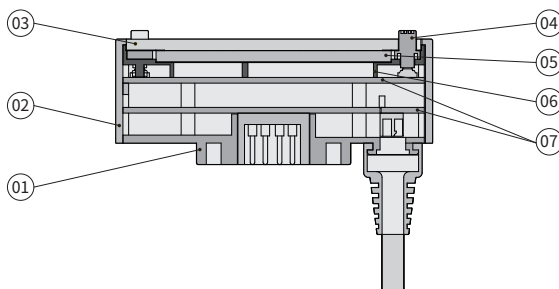

Components and material list

No.	Item	Material
01	Flow display bottom cover	Nylon
02	Cover	ABS resin
03	Acrylic display frame	Acrylic
04	Bottom	Silicone
05	LCD	LCD
06	LCD support bracket	Polycarbonate
07	Upper display module	PCB

CVTR

CVAR

CVFR

CMT

CMA

FU

MF

FPF

FP

FP-D

FPX

FPZ

FPG

FC

FC-D

FC-R

FC-J

FC-K

FP-D series Digital Differential Pressure Type Split-display Flow Meter

Dimensions

CHELIC

FPSD/ FPMD

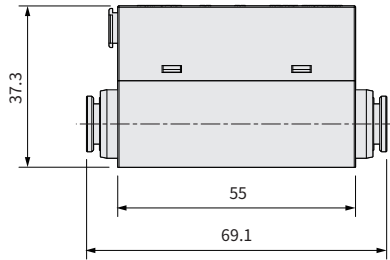
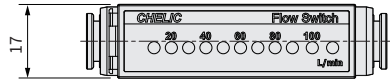
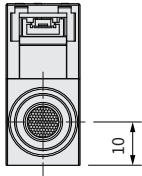

FPHD

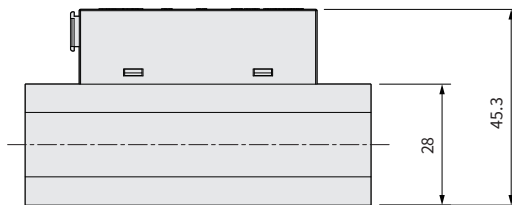
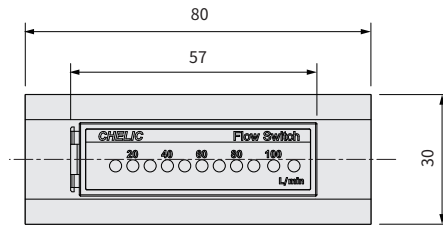
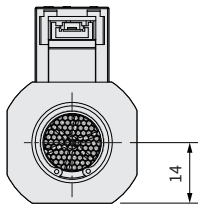

FPD Display

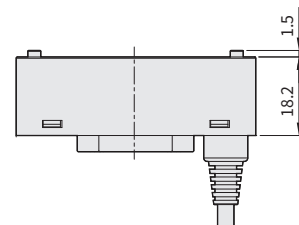
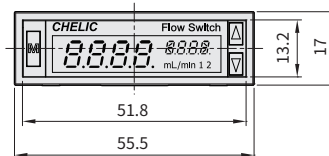
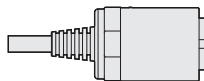

FP-D series Digital Differential Pressure Type Split-display Flow Meter

Dimensions

CHELIC

Display dimension

When FPD single unit assembled

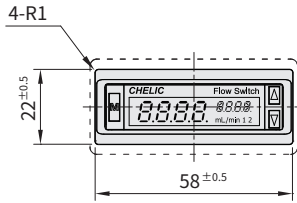

When FPD assembled in grouping

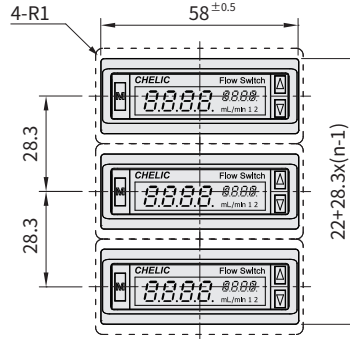

FPD Display bracket

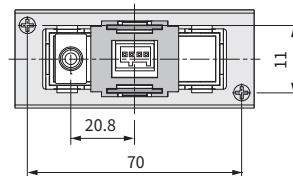
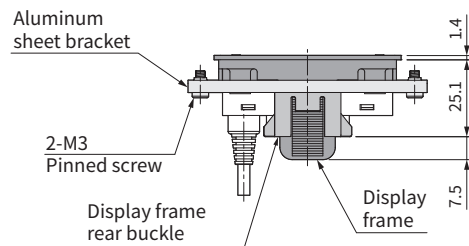
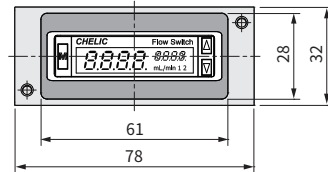
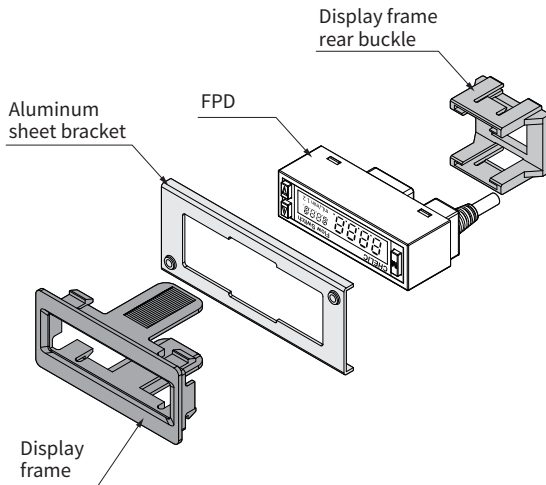

CVTR

CVAR

CVFR

CMT

CMA

FU

MF

FPF

FP

FP-D

FPX

FPZ

FPG

FC

FC-D

FC-R

FC-J

FC-K

FP-D series Digital Differential Pressure Type Split-display Flow Meter

Dimensions/ Bracket

CHELIC

■ FPSD/ FPMD Bracket

▶ When FPD single unit assembled

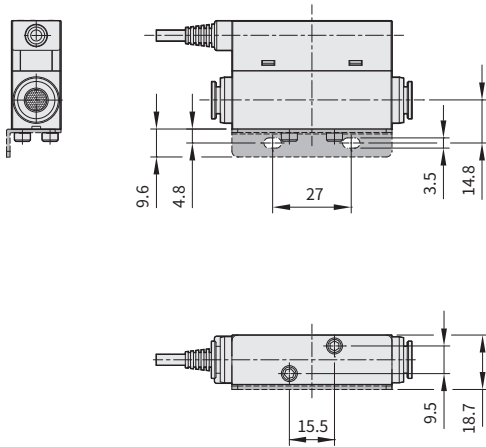

▶ When FPD assembled in grouping

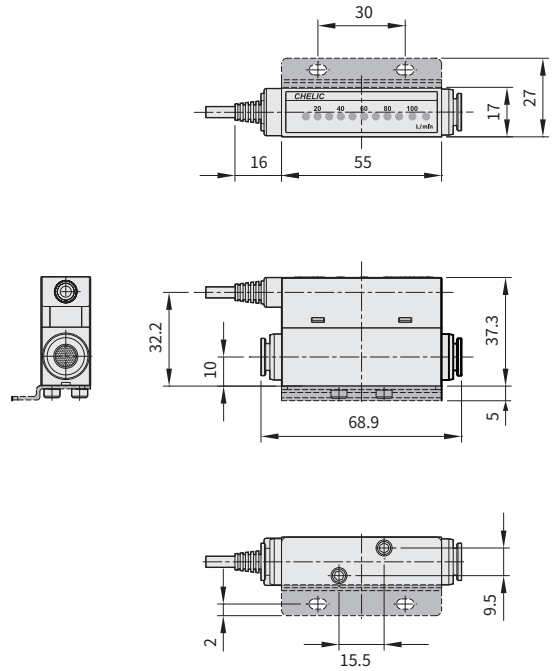

■ FPHD Bracket

▶ L type bracket- L

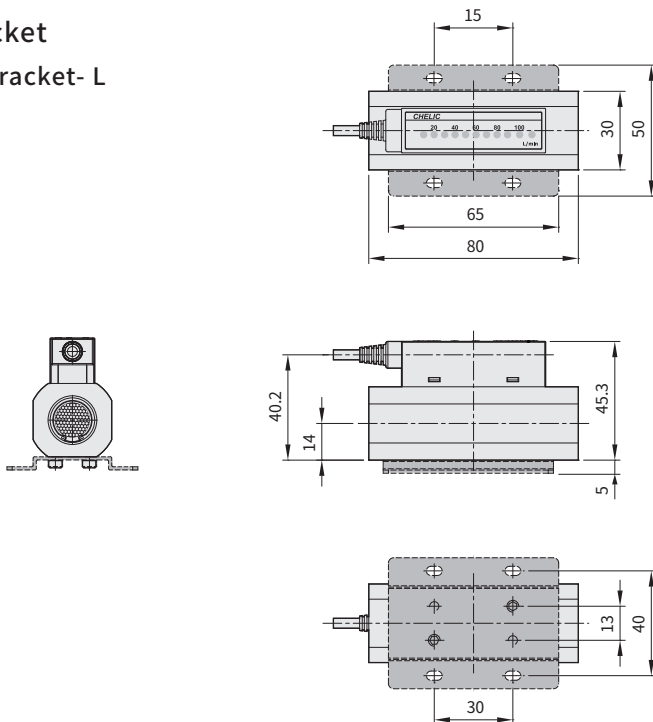

FP-D series Digital Differential Pressure Type Split-display Flow Meter

Cable assembly

CHELIC

Cable assembly

FP-D

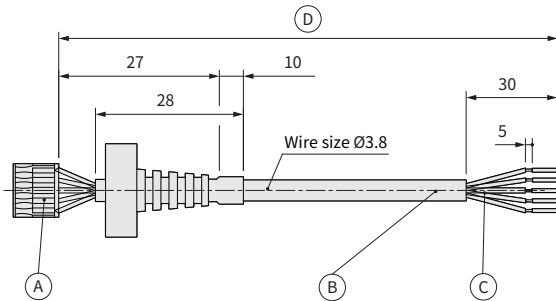

FPD

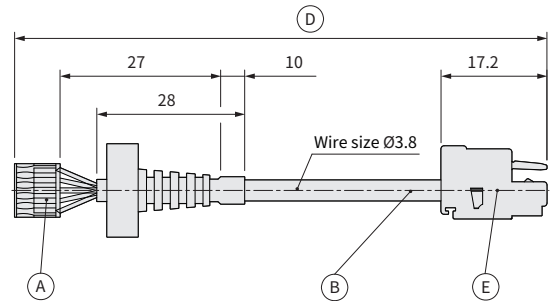

NO.	Specification	NO.	FPD connector	Specification						
(A)	5 PIN connector	(E)		Corresponding to the color wiring of the FPD wire terminal also attach a separate wiring hand tool.						
(B)	Wire: Inside (AWG26/ 5 line); cover: white									
(C)	Insulator outer diameter: About Ø1 Insulator tone: Brown, White, Black, Orange, Blue									
(D)	Wire length: L = 1000mm ± 50 or L = 3000mm ± 50									
				<table border="1"> <tr> <td>01</td> <td>02</td> <td>05</td> </tr> <tr> <td>Brown</td> <td>White</td> <td>Blue</td> </tr> </table>	01	02	05	Brown	White	Blue
01	02	05								
Brown	White	Blue								

Wire connector 1.25Px5pin

Image	PIN	Wire color	Specification
	01	Brown	Power + (24V)
	02	White	CH1(Switch output 1 : max50mA)
	03	Black	CH2(Switch output 2 : max50mA)
	04	Orange	Voltage output: 1 ~ 5 V, Load Impedance: 50 kΩ above Current output: 4 ~ 20 mA, Load Impedance: 300 Ω or less
	05	Blue	Power - (GND)

Wire connector 1.25Px5pin

Image	PIN	Wire color	Specification
	01	Brown	Power + (24V)
	02	White	Voltage output: 1 ~ 5 V, Load Impedance: 50 kΩ above Current output: 4 ~ 20 mA, Load Impedance: 300 Ω or less
	03	Black	N.C
	04	Orange	N.C
	05	Blue	Power - (GND)

Image

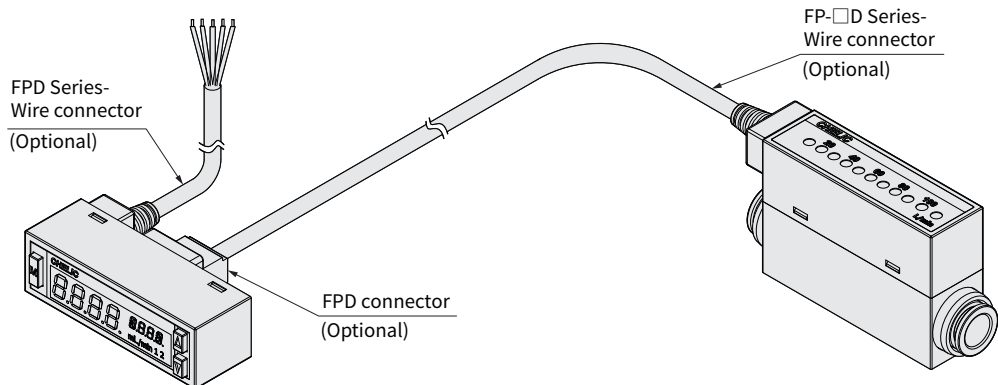

CVTR

CVAR

CVFR

CMT

CMA

FU

MF

FPF

FP

FP-D

FPX

FPZ

FPG

FC

FC-D

FC-R

FC-J

FC-K



General Cautions for FC / FP□ series

CHELIC

Applicable Fluid

DANGER

- Do not use the product with the flammable gas.

WARNING

- Let the fluid flow after adjusting the Pressure Regulating Valve.
(To avoid feeding the flow with pressure exceeding the rated value as to cause the damage.)
- Do not use the product as the metering gauge.
(This product is incompatible with the metering method. Please use it in industrial sensing purpose.)
- Do not use the fluid other than the recommended product.
- As the fluid may contain impurities, the filter should be installed at the front section.
(It should be provided with relevant air loop).

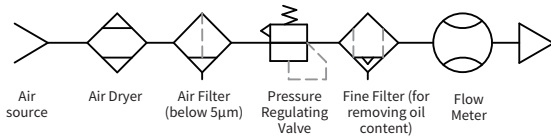

CAUTION

- Use the dry gas that does not contain corrosive compositions such as chlorine and sulfur. Further, it shall also be the clean gas without any dust or oil mist.
- Please use the pressure according to the rating specified in the Specification, otherwise it will affect the service life of the sensor.
- If the compressive air contains massive amount of condensate, then it may cause the defects of this product or other type of pneumatic components. Therefore, it should be provided with Rear Cooler, Air Dryer and Condensate Collector, etc.
- Excessive carbon powder produced by the Air Compressor may attach to the internal side of the product as to cause defective action.
- Due to the varied pressure-resistant level of the respective product model, care should be used when selecting the desired model.
(If the flow rate is exceeding the required level, it will cause the product damage.)

Applicable Environment

DANGER

- Do not use this product in an environment containing explosive gas.

WARNING

- Do not use this product in the location subjecting to surging voltage.
- Do not use this product in the corrosive environment.
- Environment temperature/ gas temperature
(This product should be used within 0~50°C of environment/ gas temperature range.)

CAUTION

- Do not use this product in an environment where temperature is violently fluctuating.
(The location subjecting to abnormal temperature change and circulation will affect the accuracy.)
- Water-resistant environment.
(Except for that FPX model belongs to IP65 class, the rest of others are rated at IP40 class. Do not install this product in a location filled with moisture, salty mist and dust to avoid damage.)

Installation

WARNING

- Please watch the flowing direction of the fluid.
(The flowing direction should be that indicated by the arrow symbol as being marked on the main body.)
- Before starting the installation, please remove the residual dirt from the pipeline with air purging method.
- Falling and tapping actions are not allowed.
(If applying excessive impact, it may lead to internal damage.)
- Please hold the main body firmly when installing the product.
(During the installation, do not drag the power cord to avoid damage that may be caused by excessive dragging force.)
- Do not install the flow meter at the position underneath the pipeline legs.

CAUTION

- The flow rate displayed in the LCD of this product may be blurred due to the angle.
When installing, keep the product from attaching to the main body too tightly. When both units are heated, it will force the temperature to rise as to cause the change of the main body or the deterioration of the resin material.
(Please maintain over 10mm of interval.)
- Please fasten the flow meter with appropriate torsional force.



General Cautions for FC / FP□ series

CHELIC

Safety notice

Wiring



DANGER

- Be sure to use the rated voltage for the voltage and the output of the power source.
(If the voltage applied is higher than the specified rating, it may cause the product damage or the electrocution and even the fire in severest scenario.)



WARNING

- Avoid the overload or the short circuit.
(This product is provided with overload protection, but it cannot prevent all of the incorrect wiring. Therefore, the wires should be carefully deployed.)
- Please confirm the insulation of the wires used.
(Prevent the wires from mixing with or contacting other type of circuit, as it may lead to over-current as to cause the damage.)
- Do not install the electrical wires and the power wires in the same wiring line.
(Please use different wires to prevent the interference from the switch-included control circuit as to cause the false action.)
- Do not execute the wiring action when the product is carrying the current.
(To avoid causing the connector damage or the electrocution risks.)
- When installing this product and the wires, please keep them away from the noise source such as the wires carrying strong current. Please also take necessary protective action to prevent the surge applied to the power cord, otherwise it may cause the change in displaying or outputting.
- Do not touch the terminal or the connecting board when the flow meter is operating.
(To avoid electrocution, operation errors or switch damage.)



CAUTION

- The cable connector of this product is provided with a protective gland in order to prevent problems that may be caused by defective reasons such as impurities.
- During the wiring process, be sure to confirm the wire color and the terminal number.
(Incorrect wiring will cause the switch damage, failure and false action. For this reason, be sure to confirm the wire color and the terminal number in the Operation Instructions before starting the wiring process. In the meantime, please also use the DC power provided with sufficient capacity and less fluctuation.)

Applicable FPF/ FC/ FP Series		
PIN No.	Wire Color	Description
01	Brown	Power + (24V)
02	Orange	Voltage output: 0.5~4.5V/1~5, with load impedance over 50kΩ. Current output: 4~20mA, with load impedance below 300Ω.
03	White	CH1 (Switch Output 1: max. 50mA)
04	Black	CH2 (Switch Output 2: max. 50mA)
05	Blue	Power - (GND)

Applicable FPX Series		
PIN No.	Wire Color	Description
01	Black	Switch Output: max. 50mA
02	Brown	Power + (24V)
03	Blue	Power - (GND)
04	White	Voltage output: 1.5 V or 0 ~ 10 V Current output: Load impedance - 4 ~ 20 mA

Please arrange the wires according to the method indicated above when inserting the cable into the socket of the main body.

Piping



WARNING

- When installing the pipeline, the anti-leakage tape should be wrapped starting from the internal side that is located over 2mm from the pipe threads and then wrap towards the thread direction and its reverse direction alternately to prevent the air leakage as to affect the accuracy.
- The pipeline connecting to the Air Compressor shall not get loosened due to vibration, releasing or tension effect.
- When using the fast coupler, be sure to insert the hose and the start the use after confirming that it is impossible to pull out the hose. When cutting the hose, be sure that the pipe is being cut into vertical profile so as to proceed with the final cutting.
- When checking the leakage of the pipeline, do not let the leakage inspection liquid flow into the product.



CAUTION

- Do not turn the connector when the product is subjected to fluid pressure, or it may cause the external leakage.
- When dismantling or replacing the pipeline port, it may present 2~3% of change in accuracy.
- The diameter of the rear-end pipe should be wider than that of this product.
- Because the flow meter of this product is designed in one-way flowing type, be sure to watch the flowing direction before starting the piping work.

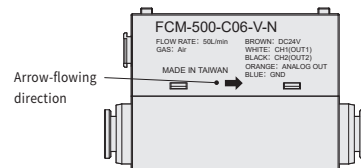



General Cautions for FC / FP□ series

CHELIC

Fluid Measuring



WARNING

- Please use this product in a location without the falling impact or vibration concern. During the installation and the moving process, this product should be handled by considering as the precision machine.
- Please confirm that the Pressure Regulating Valve or the Throttle Valve has been properly adjusted before letting the fluid flow.
(Watch the pressure upper limit, as the sensor may damage if exceeding the rated pressure.)
- To prevent foreign matters from mixing with the fluid, be sure to install additional filter at the primary side of the product in order to prevent the foreign matter from blocking as to affect the accuracy.
- When measuring the fluid, please use the fluid specified in the product catalogue.
(The accuracy will vary depending on the density of the fluid.)
- When measuring the flow rate with this product, it shall be used within the rated flow rate and the rated pressure range suitable for such model.
- Do not attempt to turn the connector when this product is applying the fluid pressure, or it may cause the external leakage of the pipeline. Further, it is also required to check if the connector is securely fixed in position.
- Be sure to starting power when the flow rate falls to the "Zero" baseline.
- Flow rate unit
(The flow meter will be measured according to the mass flow rate that will not be affected by temperature and pressure. Therefore, the measuring unit selected will be L/min which represents the volumetric flow rate by translating the mass flow rate to 00C, 101.3 kPa based volumetric flow rate.)

【FP/FPX SERIES】

- When resetting the flow rate to zero instantly (under saturated pressure), the hysteresis phenomenon will be presented for the differential pressure allowing the displayed flow to be reset to zero gradually. However, such kind of phenomenon will not happen when discharging the flow rate to the atmosphere.



CAUTION

- When using this product, be sure to set up the standby time. (longer than 5 minutes after being supplied with power).

【FC SERIES】

- When the meter is empty and when longer standby time is required, the LCD of the Thermal Mass Flow Meter may present trivial shifting sign due to internal temperature.
- When sustaining the vibration, the Needle Valve of (FC-R) Speed-regulating Flow Meter may rotate as to change the flow rate. Therefore, the knob fixing lock should be turned tightly.

【FP□ SERIES】

- After being supplied with power, this product will execute the self-diagnosis automatically and the flow rate inspection will remain inactive for a short period of time. For this reason, please set the control circuit and the program in order to ignore the signal being transmitted during the first 5 seconds of time after the product is supplied with power.
- When using this product without any fluid, be sure to supply the power and then charge the gas to ensure that the product zero point will be correctly calibrated.
- When using the Differential Flow Meter, ensure that stabilized pressure source will be provided. If the flow path outlet of the Differential Flow Meter is facing directly to the atmosphere, the sensing accuracy should be below $\pm 3\%$. In the event the rear-end of the outlet is provided with a Speed Regulating Valve for regulating the flow rate, then its sensing accuracy should be below $\pm 5\%$.
- When using FP/FPX series of larger-sized flow meter, its working pressure should be over 5 bars. If less than 5 bars, then the working scope of the measurable flow rate will be reduced accordingly.
- The flow rate will become zero during the pressure saturating process. In this case, the pressure will present trivial amount of differential change that it may cause the shifting of the zero-point value.
- The FP□ series differential pressure flow meters cannot measure vacuum flow. Please use the FC thermal mass flow meter for measuring vacuum suction flow instead.

Maintenance and Inspection



WARNING

- Please conduct the periodic inspection and confirm that the machine is operating normally.
- If failing to follow the instructions provided in the Operation Instructions, it would be impossible to ensure the machine safety.
- Do not attempt to dismantle or modify the structure of this product, as it may cause the incorrect accuracy or the sensor damage.
- When carrying out the maintenance or the inspection, be sure to stop the machine from operating, shut down the power and release the gas from the pipeline.



CAUTION

- Do not wipe this product with chemical agent such as volatile oil or thinner.
- Do not insert a rod into the pipeline to prevent from scratching the internal side.
- If any anomaly emerges during the operating process, be sure to cut off the power, stop the machine from operating and then contact the dealer.
- When using the LCD display model, do not press the display area to prevent the display panel from damage or failure.