

Clamp-on Ultrasonic Flow Meter



CHELIC

FN-V series

Clamp-on Design No Downtime

Stay clean and Elegant as no contact with fluids—resistant to scaling, corrosion, and pressure loss

Reinforced Glass Screen High Definition and Durable

Scratch-resistant, impact-resistant, excellent visibility

One-Touch Setup Easy to Use

Innovative Menu
Simple Configuration



Expandable Functions Broad Applications

Supports external pressure and level sensors

Features

Silicone membrane keypad

Good tactile feedback, long lifespan

Output status indicator

Easily check the status of the flow meter

Flow rate Status

Total Flow Date

Switch Output

TFT full-color screen, displays multiple data in high resolution

Metal clamp-on structure

Lightweight, easier to setup



Applicable Fluids

Measurable Fluid Conditions



1. Stable Flow Velocity in Pipe
2. Pressure Maintained at 0.3 kg/cm²
3. Fluid Temperature Within 85°C
4. Won't produce bubbles (cavitation) due to flow

Pipe Materials

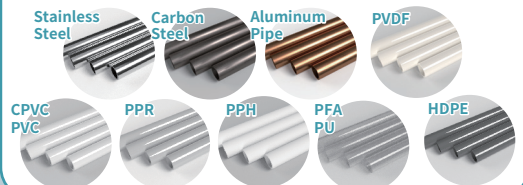

This product series is used in industrial IoT systems.

FN-V series Clamp-on Ultrasonic Flow Meter

Specification

CHELIC

Specifications

Item	Model	FN-V										
Applicable Pipe Size	Outer Pipe Diameter	Ø13-Ø16	Ø16-Ø18	Ø18-Ø23	Ø23-Ø28	Ø28-Ø37	Ø37-Ø44	Ø44-Ø52	Ø52-Ø64	Ø64-Ø83	Ø83-Ø100	Ø100-Ø127
	Metric Units	DN08	DN10	DN15	DN20	DN25	DN32	DN40	DN50	DN65	DN80	DN100
	Nominal Diameter (B)	1/4"	3/8"	1/2"	3/4"	1"	1 1/4"	1 1/2"	2"	2-1/2"	3"	4"
Pipe Material		Metal pipes, rigid resin pipes										
Fluid Temperature	°C	0° C to 85° C (Pipe surface must not be frozen) Note 9										
Maximum Flow Rate	L/min	19.6	30.6	53	94.2	147.3	241.3	377	589	996	1508	2356
Zero Cut-Off Flow Rate	L/min	0.3		0.5		1.0			6	10	15	25
Detection Principle		Transmission Time Difference										
Display		TFT2.0"										
Display Refresh Cycle		4 times/sec										
Resolution	Instantaneous Flow L/min	0.01/0.1/1										
	Totalized Flow L	0.01 / 0.1 / 1 (up to 8 digits)										
Response Time	s	0.5/1.0/2.5/5.0/10.0										
Measurement Accuracy	At 10% to 100% of F.S.	±2% of F.S. Note 1, 2, 3										
	At 0% to 10% of F.S.	±1% of F.S. Note 1, 2, 3										
Repeatability F.S. Note 2, 4	%	±0.8										
Hysteresis (Deadband)		Variable										
Flow Unit		L/min, m ³ /h										
Pulse Output Unit	L	0.1 ~ 999.99										
Data Retention Time		Approx. 1 year										
Power I/O Connector		M12 8-pin connector										
Output	Switch Output	Instant/Window/Pulse/Accumulated/Error/No Signal NPN/PNP switchable open collector output: ≤ 26.4 VDC, ≤ 20 mA/ch, residual voltage ≤ 2.5 V										
	Analog Output	1 ~ 5 V / 0 ~ 10 V (switchable) load impedance: 50kΩ 4 ~ 20 mA / 0 ~ 20 mA (switchable) Load resistance: ≤ 300 Ω Note 5										
Power Supply	Supply Voltage	DC24V±10% Note 6										
	Current Consumption	≤ 200 mA Note 7										
Protective Circuit Note 8		Power reverse protection, surge protection, output short-circuit protection										
Environmental Resistance	Enclosure Protection Rating	IP65/IP67 Note 9, 10										
	Operating Temperature °C	- 20 ~ +60 (no freezing)										
	Operating Humidity %	Operating humidity: 35% to 85% RH (non-condensing)										
	Vibration Resistance	10Hz to 500 Hz power spectral density: 0.816 G ² /Hz (X, Y, Z directions)										
Menu Language		Traditional Chinese · English										
Relay Output		Relay output: ≤ 27VDC, max 250mA, freq. <2Hz										
Communication Interface		RS-485 (MOBUS RTU)										
Calendar Battery		CR1220										
Applicable Medium		Water, solution, chemical reagents (impurities ≤ 4%)										
Applicable Viscosity (mm ² /s)		<300CST										
Certification and Standards		CE & UL Note 11 EMC 2014/30/EU ; EN 61326-1 UL 61010-1 , EN 61010-1 IEC 61157 RoHS 2011/65/EU Exceptions: III 7cl/IV 15 ; RoHS 2015/863										
Weight g		316	309	392	503	401	406	416				

- Note: 1. The ultrasonic-measured liquid must not contain large amounts of bubbles. Measurement may become unstable depending on pipe material and conditions.
 2. Errors may occur due to the type of piping, condition, fluid type, and fluid temperature used by the customer.
 3. Zero-point adjustment was performed in a controlled environment at 25° C, considering linearity error.
 4. The definition assumes a stable velocity distribution. It does not account for pulsations or variations caused by equipment.
 The stated F.S. (Full Scale) should be interpreted using the rated flow range.
 5. The output impedance of the analog voltage type is approximately 1 kΩ. If the load impedance is low, the output value may differ significantly.
 Please verify and account for load impedance error before use.
 6. DC24V connection current varies depending on whether a load is connected. Consumption current may also vary. Please take special care.
 7. Load current must be below 200 mA. (Excluding expansion module)
 8. The built-in protection circuit only covers specific error conditions and load short circuits. It does not guarantee protection against all wiring errors.
 9. This item is not UL certified.
 10. Compliant with IEC 60529; standard protection rating is IP65, and an IP67 waterproof specification is available upon request.
 11. CE (DN50-DN100) and UL certifications — applications in progress.

FN-V series Clamp-on Ultrasonic Flow Meter

CHELIC

Product features, Code of order

Feature

- Suitable for various fluids
- Compatible with various pipe materials
- Measures outer pipe diameter directly; no tapping or fluid contact required
- Easy setup: enter pipe size to begin measuring
- No wetted parts, no clogging or corrosion, zero pressure loss
- Installation is possible without stopping the system



Code of order **FN-V-D10 - W3 - C - MJ**

1 — 2 — 3 — 4

1

Pipe		
Mark	Pipe Size(inch)	Pipe Size(mm)
D08	1/4"	13 ~ 16
D10	3/8"	16 ~ 18
D15	1/2"	18 ~ 23
D20	3/4"	23 ~ 28
D25	1"	28 ~ 37
D32	1 1/4"	37 ~ 44
D40	1 1/2"	44 ~ 52
D50	2"	52 ~ 64
D65	2 1/2"	64 ~ 83
D80	3"	83 ~ 100
D100	4"	100 ~ 127

2

Mark	M12-8 Pin Cable
None	Without Cable
W3	3m
W10	10m



M12-8P-F

3

Mark	Transparent Protective Cover
None	Without Transparent Protective Cover
C	Transparent Protective Cover

4

Mark	External Connector
None	Without External Connector
MJ	M12-4 PIN External Connector

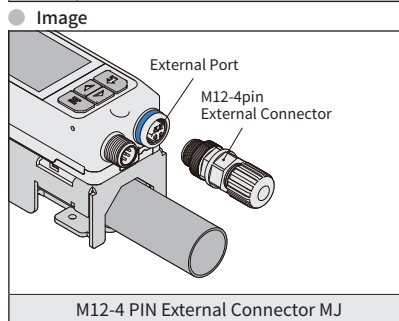

- Analog Input for Pressure Sensor
- Analog Input for Level Sensor

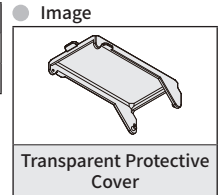

※Anti-splashing water and prevent accidental operation

Flow range

Model	FN-V-D08	FN-V-D10	FN-V-D15	FN-V-D20	FN-V-D25	FN-V-D32
Pipe Diameter (Metric Units)	DN08	DN10	DN15	DN20	DN25	DN32
Minimum Flow Rate (L/min) Note 1	0.6	0.9	1.1	1.9	2.9	4.8
Maximum Flow Rate (L/min) Note 2	19.6	30.6	53	94.2	147.3	241.3

Model	FN-V-D40	FN-V-D50	FN-V-D65	FN-V-D80	FN-V-D100
Pipe Diameter (Metric Units)	DN40	DN50	DN65	DN80	DN100
Minimum Flow Rate (L/min) Note 1	7.5	11.8	19.9	30.2	47.1
Maximum Flow Rate (L/min) Note 2	377	589	996	1508	2356

Note : 1. For minimum flow rate Ø15 and above, flow is calculated at 0.1 m/s velocity; for Ø15 and below, at 0.2 m/s.
2. For maximum flow rate Ø15 and above, flow is calculated at 5.0 m/s velocity; for Ø15 and below, at 6.5 m/s.

FN-V series Clamp-on Ultrasonic Flow Meter

CHELIC

Model Selection Procedure

Step 1 Select Pipe Size

Pipe Size	Ø13 ~ Ø16	Ø44 ~ Ø52
	Ø16 ~ Ø18	Ø50 ~ Ø65
	Ø18 ~ Ø23	Ø65 ~ Ø75
	Ø23 ~ Ø28	Ø80 ~ Ø90
	Ø28 ~ Ø37	Ø100 ~ Ø115
	Ø37 ~ Ø44	

Confirm the appropriate pipe size.
(Avoid selecting a pipe size that is too large or too small, which may result in measurement failure.)

Step 2 Confirm Pipe Material

Pipe Material	Stainless Steel	PVC
	Carbon Steel	PPR
	Steel Pipe	PPH
	PVDF	PFA
	CPVC	HDPE

Since different industries use various pipe materials, confirm that the pipe material is supported before use.

Step 3 Confirm Liquid Type

Liquid Type	Water
	Oil
	Solution
	Chemical reagent

(Impurities ≤ 4%)

Step 4 Confirm Installation Environment

Step 5 Select Cable / Connector

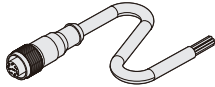
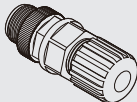
	Image	Description
Cable		Selectable cable options: none, 3 m, or 10 m.
		Selectable connector options: none, or M12-4-pin external connector.

FN-V series Clamp-on Ultrasonic Flow Meter

CHELIC

Product features, Dimensions

Internal structure

▶ D08~D50

▶ D65~D100

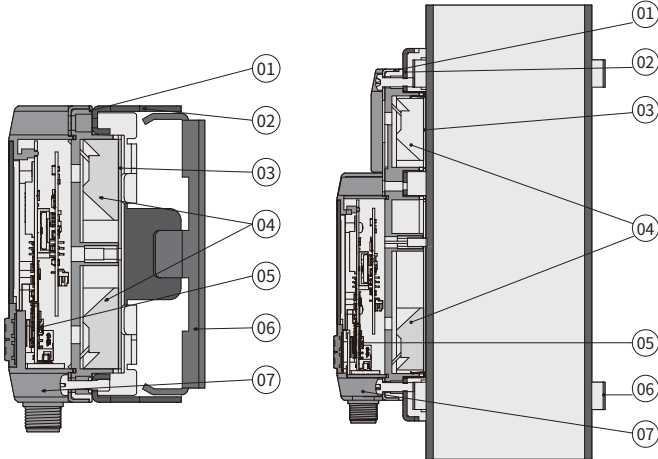

Components and material list

No.	Item	Material
01	Base Plate	PPS
02	Upper Clamp Tube	SUS
03	Ultrasonic Coupling Gel	Coupling Material
04	Ultrasonic Module	PEI
05	PCB Module	PCB
06	Lower Clamp Tube	SUS
07	Top Cover	PPS

Dimensions - DN08 ~ DN50

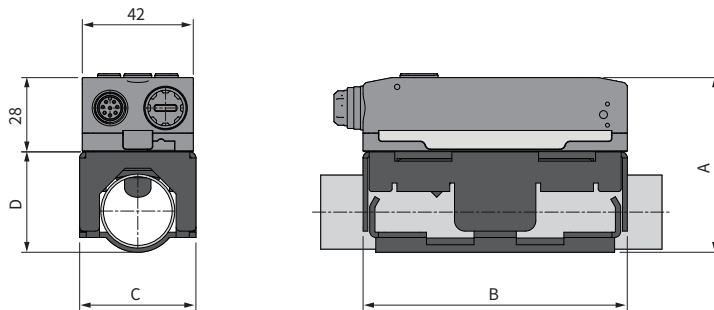

Unit: mm

Model	FN-V-D08	FN-V-D10	FN-V-D15	FN-V-D20	FN-V-D25	FN-V-D32	FN-V-D40	FN-V-D50
Pipe Outer Diameter	Ø13 ~ Ø16	Ø16 ~ Ø18	Ø18 ~ Ø23	Ø23 ~ Ø28	Ø28~Ø37	Ø37~Ø44	Ø44~Ø52	Ø52~Ø64
Pipe Diameter	DN08	DN10	DN15	DN20	DN25	DN32	DN40	DN50
A	60.4	59.1	60.9	66.4	74.3	81.9	87.8	99.7
B	100	100	100	100	100	100	100	100
C	48	48	48	48	64	64	84	84
D	30	30	30.3	37.2	43	52.3	56.3	70

FN-V series Clamp-on Ultrasonic Flow Meter

Dimensions

■ Dimensions - DN65 ~ DN100

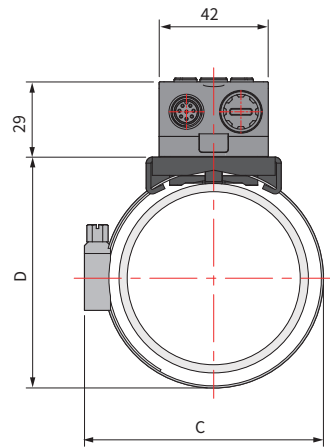
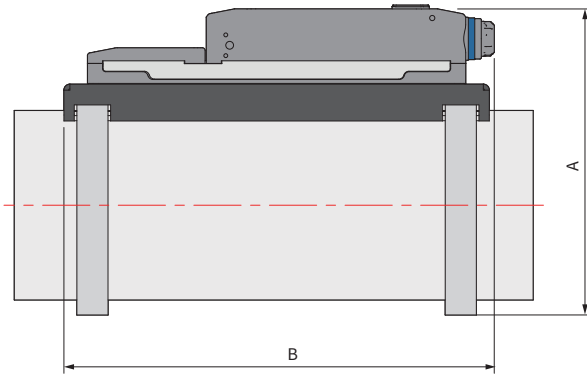
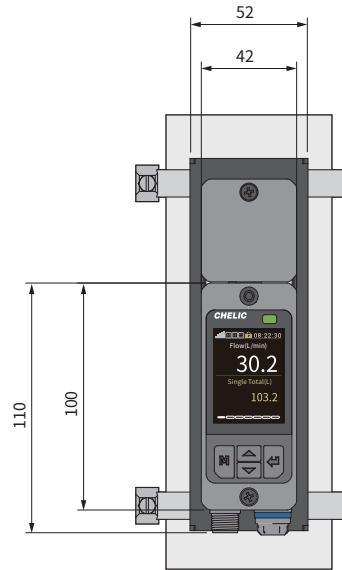

Unit: mm

Model	FN-V-D65	FN-V-D80	FN-V-D100
Pipe Outer Diameter	Ø64 ~ Ø83	Ø83~Ø100	Ø100~Ø127
Pipe Diameter	DN65	DN80	DN100
A	113	129	155
B	165	165	165
C	85	101	126
D	81	98	123

FN-V series Clamp-on Ultrasonic Flow Meter



Optional Size

Ultrasonic Flow Meter Power Cable (Optional)

► M12 Power Cable

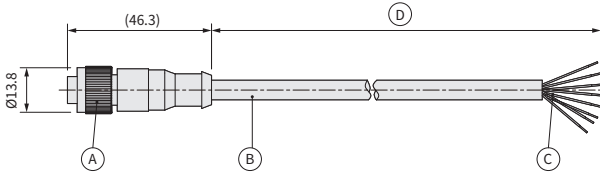

No.	Description
(A)	M12-8PIN Connector (Female)
(B)	Cable: Internal (AWG24 / 8 cores), Outer jacket: Black
(C)	Insulator Outer Diameter: approx. Ø1.1
	Insulator Colors: Brown, White, Blue, Yellow, Gray, Pink, Green, Red
(D)	FN-W3: L=3000mm ± 50
	FN-W10: L=10000mm ± 50

■ Pin Assignment

Image	PIN	Wire Color
	01	White
	02	Brown
	03	Blue
	04	Yellow
	05	Gray
	06	Pink
	07	Green
	08	Red

Protective Cover (Optional Accessory)

► Protective Cover

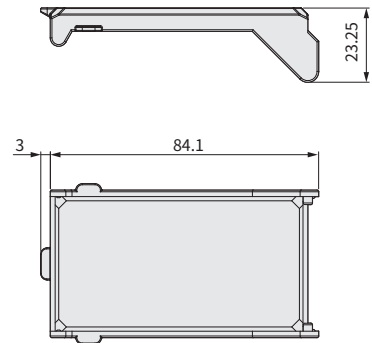
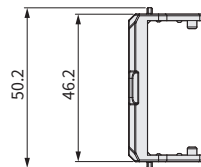
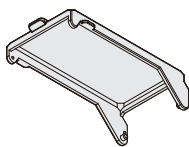

External Connector (Optional Accessory)

► M12-4pin External Connector

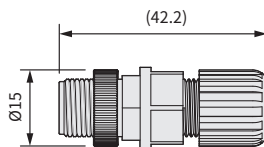
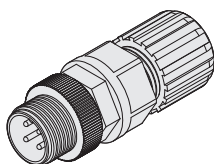

■ Pin Assignment

PIN	Function
01	DC24V
02	Current Input
03	GND
04	Voltage Input

FN-V series Clamp-on Ultrasonic Flow Meter



Accessory Model List

Accessory Model List

Clamp Bracket Model List

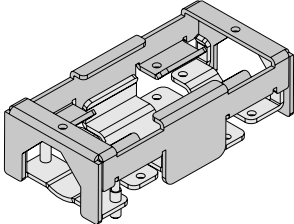
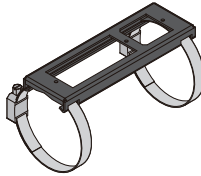
	Model	Description	Remarks
	FN-08	DN08 Pipe Clamp Bracket	Applicable Pipe Size Metric 13-16mm
	FN-10	DN10 Pipe Clamp Bracket	Applicable Pipe Size Metric 16-18mm
	FN-15	DN15 Pipe Clamp Bracket	Applicable Pipe Size Metric 18-23mm
	FN-20	DN20 Pipe Clamp Bracket	Applicable Pipe Size Metric 23-28mm
	FN-25	DN25 Pipe Clamp Bracket	Applicable Pipe Size Metric 28-37mm
	FN-32	DN32 Pipe Clamp Bracket	Applicable Pipe Size Metric 37-44mm
	FN-40	DN40 Pipe Clamp Bracket	Applicable Pipe Size Metric 44-52mm
	FN-50	DN50 Pipe Clamp Bracket	Applicable Pipe Size Metric 52-64mm
	FN-65	DN65 Pipe Clamp Bracket	Applicable Pipe Size Metric 64-83mm
	FN-80	DN80 Pipe Clamp Bracket	Applicable Pipe Size Metric 83-100mm
	FN-100	DN100 Pipe Clamp Bracket	Applicable Pipe Size Metric 100-127mm

8-pin Dedicated Power Cable (Optional)

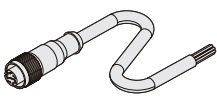
	Model	Summary
	FN-W3	M12-8 Core Power Cable 3m
	FN-W10	M12-8 Core Power Cable 10m

Protective Cover (Optional)

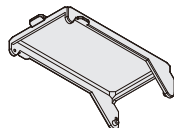
	Model	Summary
	FN-C	Transparent Cover

Expansion connector option(Optional)

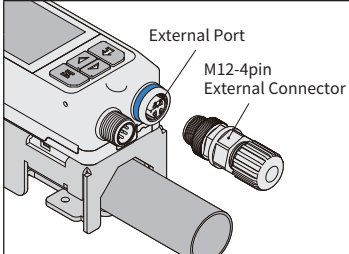
	Model	Summary
	MJ	M12-4pin External Connector Pressure Sensor (Analog Input) Liquid Level Sensor (Analog Input)

Measurement Principle

The FN-V series adopts the V-path ultrasonic measurement method. By detecting the time difference between ultrasonic waves traveling upstream and downstream through the liquid, the flow rate corresponding to various pipe sizes can be accurately calculated.

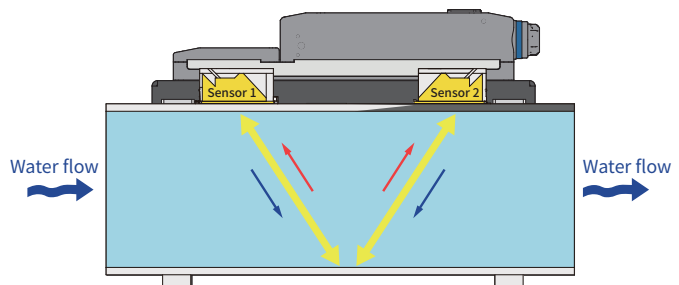

FN-V series Clamp-on Ultrasonic Flow Meter

CHELIC

Installation

Installation Steps

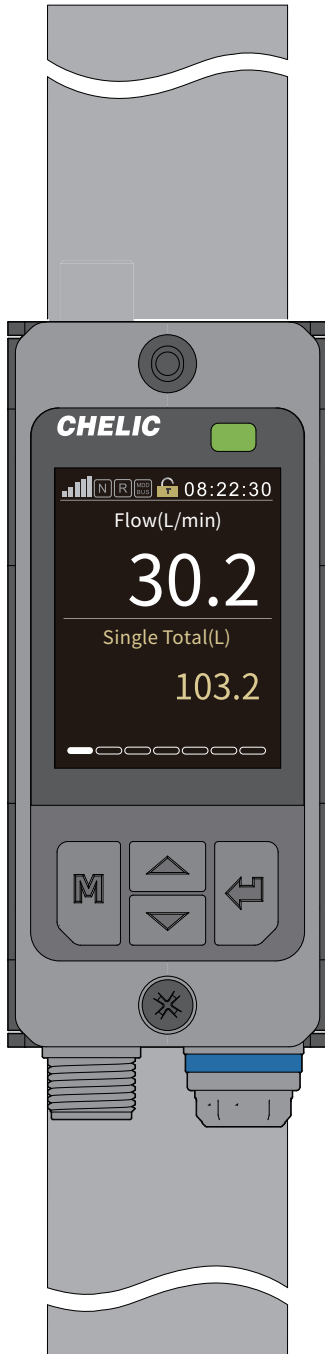

1. Confirm that the pipe is clean; wipe away any oil inside and outside the pipe.

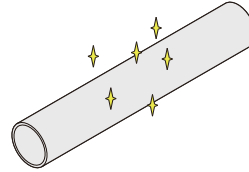

2. Clamp the pipe in place and tighten it.

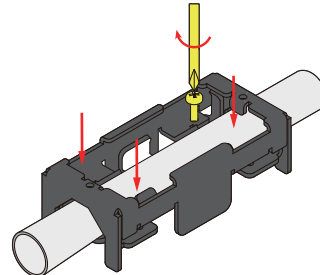

3. Please ensure if silicone base of the main unit is free from dirt or residue.

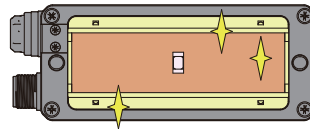

4. Mount the main unit onto the pipe and secure it with screws.

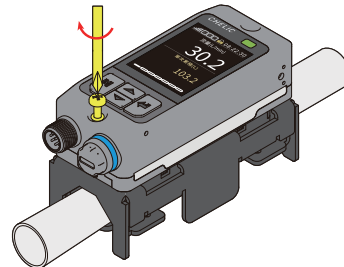

5. Connect the power cable to the main unit to begin flow detection.

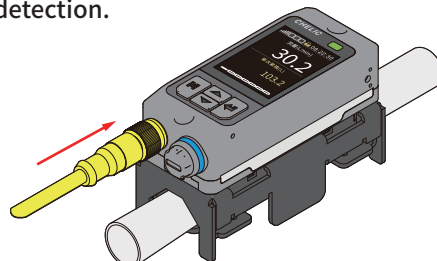

Note: After allowing water to drip inside the pipe, conduct a static dripping test and check whether the upper left corner shows a signal . If no signal appears, ensure the pipe is properly secured.

FN-V series Clamp-on Ultrasonic Flow Meter

Installation

Installation Steps - DN65-DN100



1. Ensure the pipeline is clean and remove any oil or contaminants from both the inner and outer surfaces.

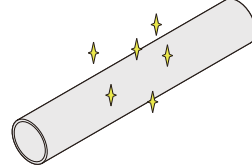

2. Assemble the ultrasonic sensor mounting bracket onto the target pipe and tighten the two designated fastening points securely.

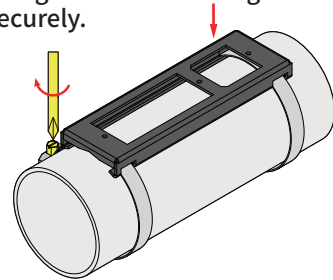

3. Check whether the silicone pad on the sensor base is free of dirt or debris.

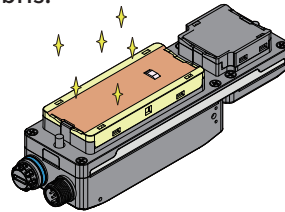

4. Assemble the ultrasonic sensor onto the mounting bracket and securely tighten the three designated fastening points.

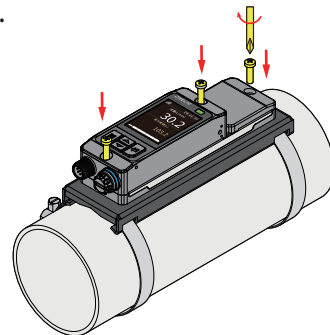

5. Connect the cable to the main unit, power on, and begin flow detection.

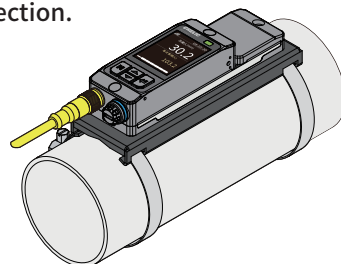

Note: After allowing water to drip inside the pipe, conduct a static dripping test and check whether the upper left corner shows a signal . If no signal appears, ensure the pipe is properly secured.

FN-V series Clamp-on Ultrasonic Flow Meter

Installation and Wiring

Installation and Wiring

PC settings

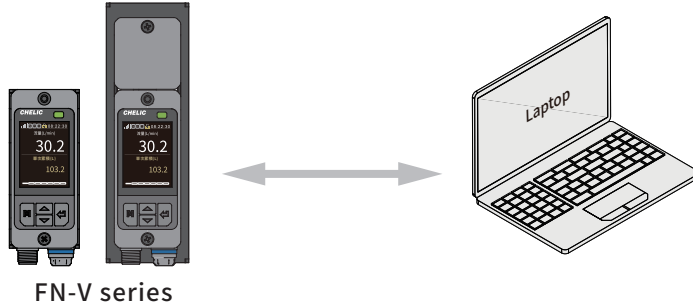

M12 Power Cable Connection

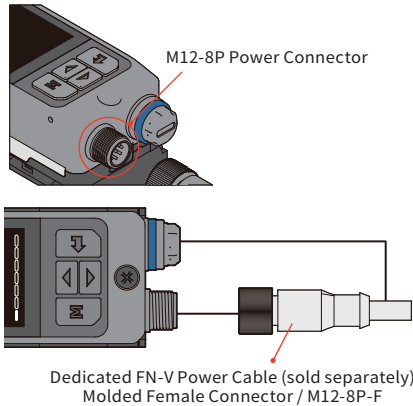

Connect to Expansion Port (Optional by Requirement)

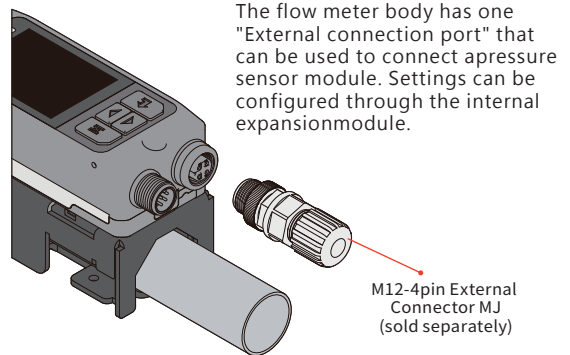

Wiring

Unused input wires must be individually insulated.

□ Load (input device) ⚡ Analog voltage/current input device

1. Wiring for switch output channel

● NPN

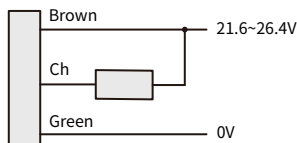

● PNP

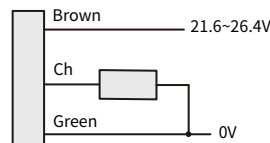

2. Wiring for analog output channel

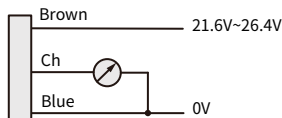

3. Wiring for relay output channel

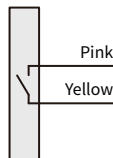

*Selectable output:
0~20mA / 4~20mA / 1~5V / 0~10V
(via configuration)

M12 Port Description

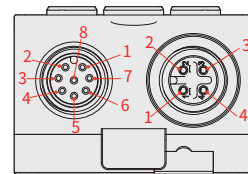

Output Channel Description

PIN	Wire color	M12-8P Description
1	White	RS485 B
2	Brown	Power DC24 ± 10%
3	Blue	GND
4	Yellow	Relay Output
5	Grey	Wiring for analog output 0~20mA/4~20mA/0~10V/1~5V
6	Pink	Relay Output
7	Green	RS485 A
8	Red	Switch Output

Input Channel Description

PIN	M12-4P Description
1	Power DC24 ± 10%
2	Current Input: 4~20 mA
3	GND
4	Voltage Input: 1~5 V

FN-V series Clamp-on Ultrasonic Flow Meter

CHELIC

Reference for Installation Setup

Setting Operation

1. Enter Menu Mode

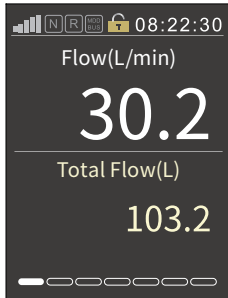

Press **M** on the main screen to enter the menu.

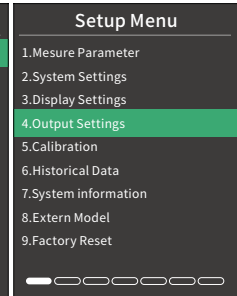
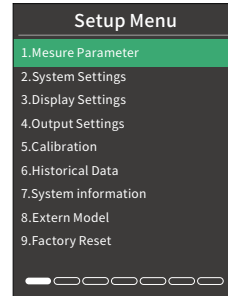

2. Set Pipe Outer Diameter and Wall Thickness

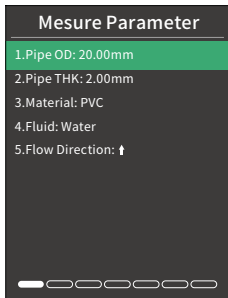

Use to set outer diameter and wall thickness, then press



3. Set Pipe Material

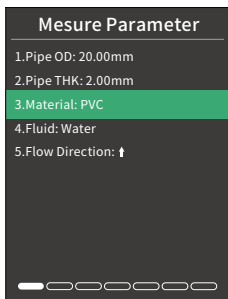

Use to select pipe material, then press

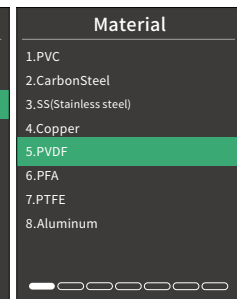
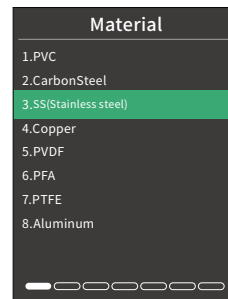
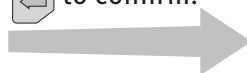

4. Set Fluid Type

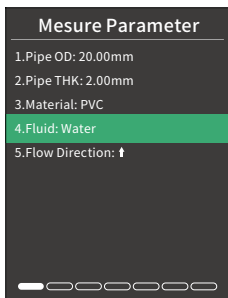

Use to select fluid type, then press

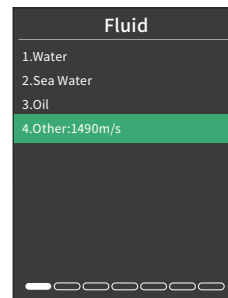

Note: If other fluids are used, select "Other" and configure fluid velocity based on the flow parameter table.

FN-V series Clamp-on Ultrasonic Flow Meter



Reference for Installation Setup

Zero Point Calibration

When using a new product for the first time, perform zero point calibration. During calibration, ensure the pipe is fully filled with fluid (medium) and free of air bubbles. Close the valve to make the fluid stationary, then proceed with zero point calibration.

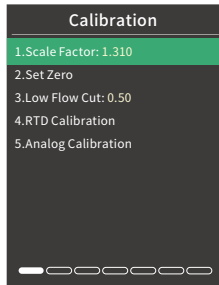
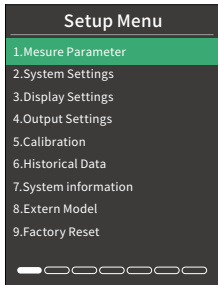

1. Press **M** on the main interface to enter the menu settings.

2. Select “Set Static Zero Point” .

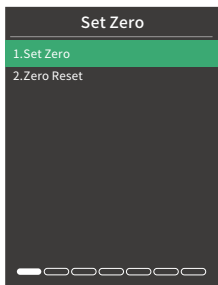

3. Click on the static zero point setting option.

Open the valve to measure flow normally.

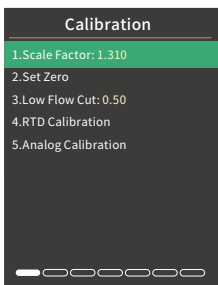

5. After completion, it will automatically return to the calibration interface.

Note: If it is not possible to close the valve on site, this operation can be skipped.

Fluid Property Table

Common Liquid Speed of Sound and viscosity		
Liquid	Speed of Sound (m/s)	Viscosity
Water 20° C	1482	1.0
Water 50° C	1543	0.55
Water 75° C	1554	0.39
Water 100° C	1543	0.29
Water 125° C	1511	0.25
Water 150° C	1466	0.21
Water 175° C	1401	0.18
Water 200° C	1333	0.15
Water 225° C	1249	0.14
Water 250° C	1156	0.12
Acetone	1190	
Methanol	1121	
Ethanol	1168	
Alcohol	1440	1.5
Ethanone	1310	
Acetaldehyde	1180	
Ethylene Glycol	1620	
Glycerol	1923	1180
Gasoline	1250	0.8
No.66 Gasoline	1171	
No.80 Gasoline	1139	
No.0 Gasoline	1385	
Benzene	1330	
Ethylbenzene	1340	
Toluene	1170	0.69
Carbon Tetrachloride	938	
Kerosene	1420	2.3
Petroleum	1290	
Turpentine	1280	
Trichloroethylene	1050	0.82
Peanut Oil	1472	
Olive Oil	1502	
Acetic Acid	1159	1.162
Spindle Lubricating Oil	1342	15.7

FN-V series Clamp-on Ultrasonic Flow Meter

CHELIC

Piping Installation Example

Straight Pipe Section

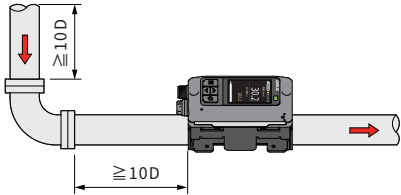
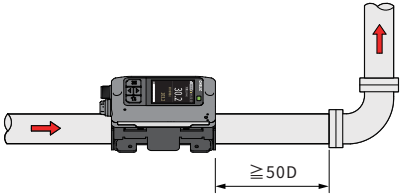
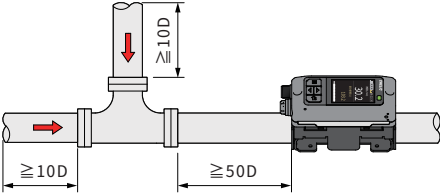
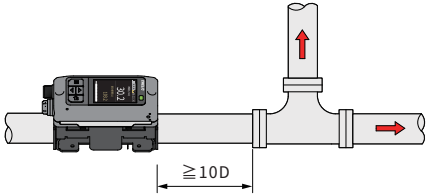
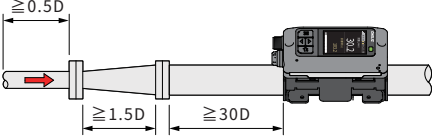
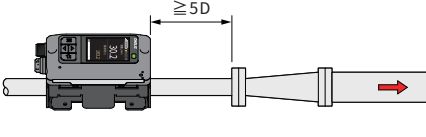
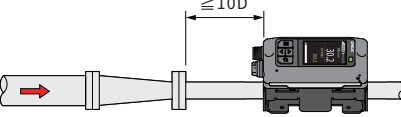
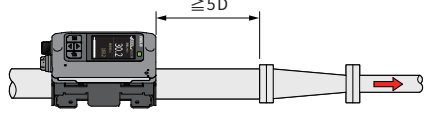
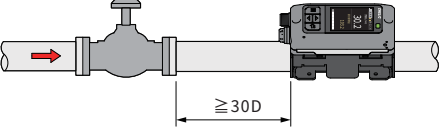
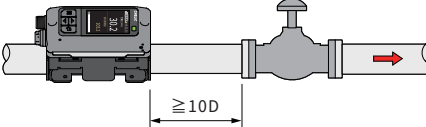
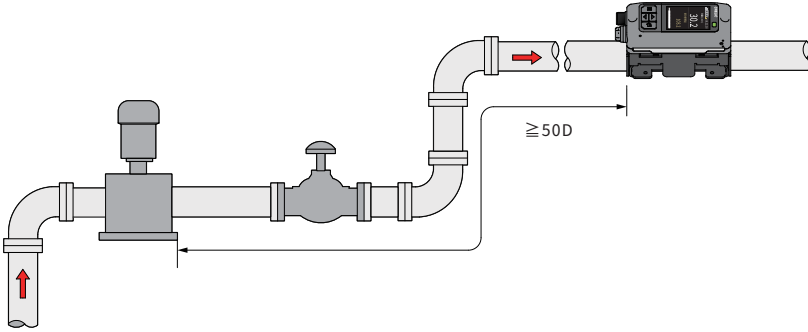
Site	Straight Pipe Before Installation Point	Straight Pipe After Installation Point
Elbow		
Tee Pipe		
Enlarging Pipe		
Reducing Pipe		
Valve		
Pump		

Note: 1. D refers to the inner diameter of the pipe.



- Installation recommendation: To ensure stable measurement and avoid interference from air bubbles or sediment, do not install the sensor at the top of the pipe (12 o' clock position). It is recommended to install it on the side of the pipe or slightly upward at a 30° -45° angle to ensure the pipe remains fully filled and maintains a stable flow profile.
- Straight-run recommendation: To stabilize the flow profile and obtain accurate measurement results, provide at least 10D of straight pipe upstream and 5D downstream of the sensor (D = inner pipe diameter). For example, for DN25 with an approximate inner diameter of 28 mm, the recommended upstream length is ≥ 280 mm and downstream length is ≥ 140 mm.

FN-V series Clamp-on Ultrasonic Flow Meter

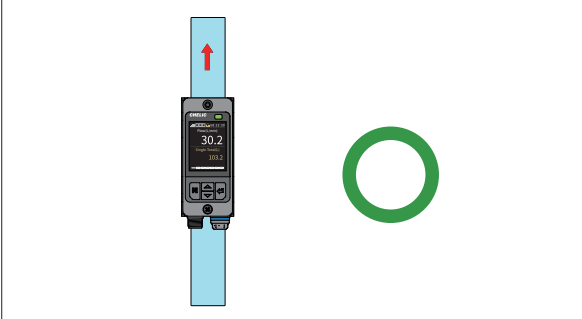

Piping Installation Example

Recommended Piping Method

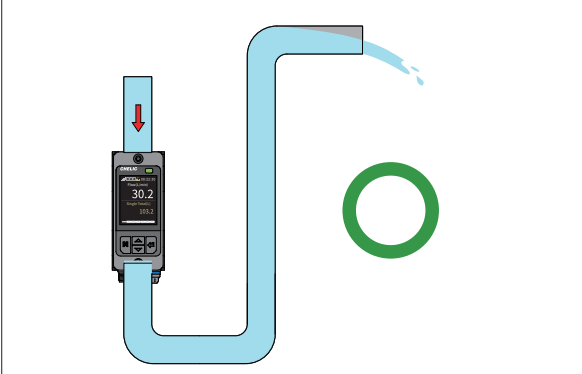
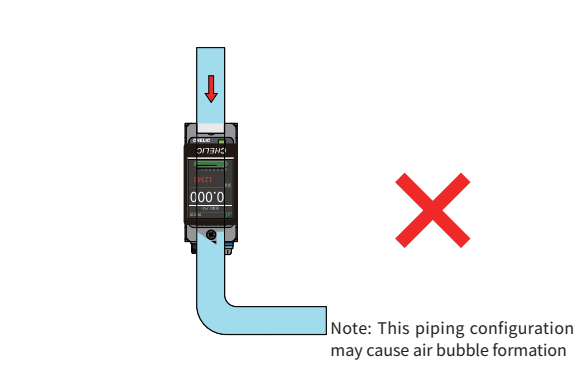
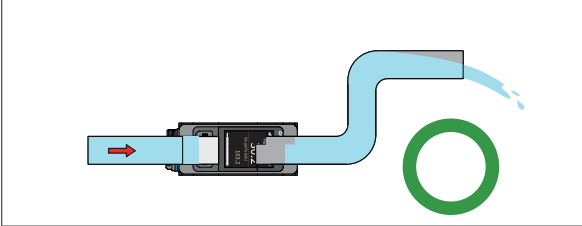
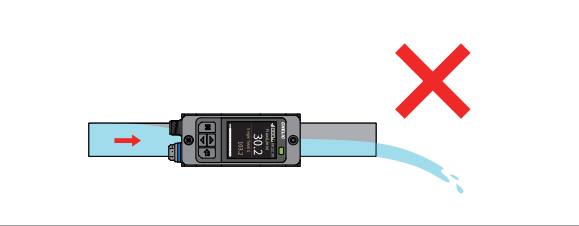
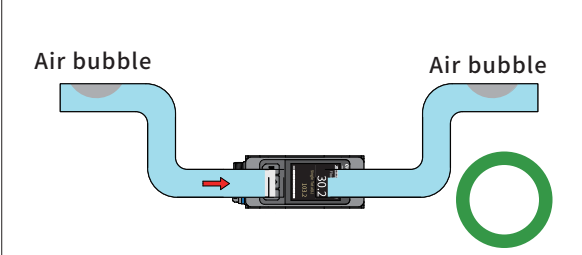
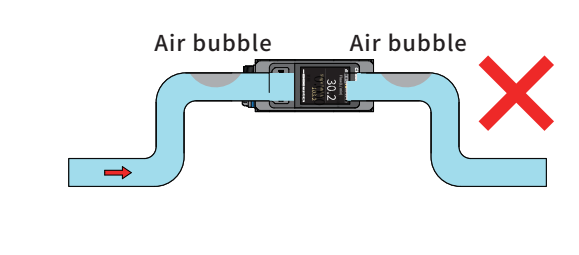
Recommended Piping Configuration	Not Recommended Piping Configuration
	 <p data-bbox="1033 645 1283 712">Note: This piping configuration may cause air bubble formation due to the flow direction.</p>
	 <p data-bbox="1033 1031 1283 1087">Note: This piping configuration may cause air bubble formation</p>
	
	

Piping Guidelines:

- 1.Ensure the flow path is completely filled with water and that there are no air bubbles in the pipe, as they may affect ultrasonic sensor accuracy.
- 2.Before zero-point calibration, fill the pipe completely and ensure the fluid is stationary.
- 3.Do not allow any gas to mix inside the pipe.
- 4.Confirm the flow direction of the ultrasonic flow meter during installation.